



MOUNTING INSTRUCTIONS

MEM-9980 Fats/Slims Mounting Kit for Kawasaki 1600 Vulcan Classic

⚠ WARNING

Read and follow these directions carefully. During installation, make certain that when turning the forks, there can be no interference with wiring or cables **AND**, that the windshield can not hit the gas tank, through the windshield's full range of adjustment.

This is a quick change kit, **ALWAYS** tighten all mounting bolts after removing or installing the windshield!

The improper installation of this kit and related components could result in serious injury or death.

Additional tools required, that are not included in this kit. 7/16" or 11mm wrench or 1/4" drive sockets and ratchet.

1. Cover gas tank and front fender with towels to avoid damage during installation.

2. Locate the upper and lower mounting bolts located on the sides of the front fork covers and remove them.

3. Using the new bolts and spacers included, loosely install the new top bolt assembly (longer bolt and wider spacer) and lower bolt assembly (shorter bolt and narrower spacer).

(see Figure 1) *Note: Use wide spacers and longer bolts on the upper mounting holes and in the lower mounting holes, use the shorter bolts and narrow spacers.*

4. Attach the windshield to the windshield mounting plates using the bottom and third bolt on each side. Leave the Nylon washers off. The Mounting tabs should be pointing in towards the headlight when installed correctly. (See Figure 2)

5. With the mounting bolts loose, slip the windshield assembly onto the mounting bolts. Adjust the angle and height and tighten all bolts. (see Figure 3)

Note: This is a quick change kit. Always tighten all mounting bolts after removing or installing the windshield.

CAUTION

IMPORTANT CARE AND CLEANING INSTRUCTIONS

Memphis Shades Windshields and Lowers are made of Lucite® acrylic, and will last for years with proper care. Clean your windshield with plenty of soapy water — mild dishwashing liquid is best — and a soft cotton cloth. Use your bare hand to feel and dislodge bugs, or cover with a wet soapy towel and let it soak. Don't use paper towels and don't scrape with anything. Small scratches can be removed with NOVUS # 2.

NEVER use any glass cleaning products, petroleum based chemicals, or cleaning agents with ammonia, bleach or any other harsh chemicals. This includes (but not limited to) RainX, brake fluid, acetone, paint thinner, benzene and gasoline. "If it hurts your nose, it will hurt the plastic."

Glass cleansing agents will cause severe damage to your windshield, and will void your warranty.

NOTE: At certain times of the day the Sunlight can reflect off the curvature of a windshield and cause extreme heat build-up on motorcycle instruments and instrument panel. Take care when parking. Park facing the sun, place an opaque object over the instruments or adjust the windshield to avoid reflections.

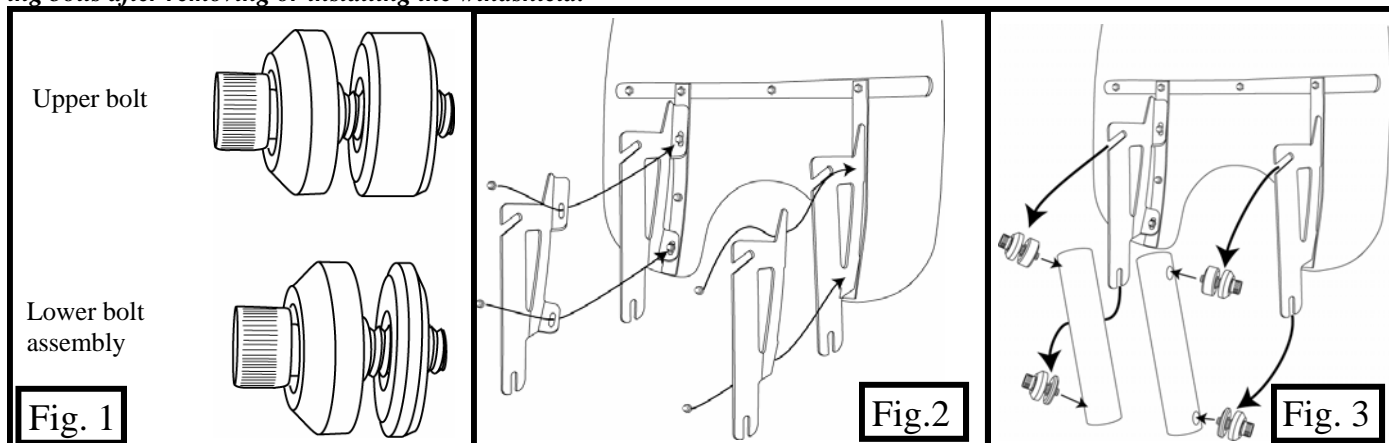



MOUNTING INSTRUCTIONS

MEM-9980 Fats/Slims Mounting Kit for Kawasaki 1600 Vulcan Classic

PART #	DESCRIPTION	QTY.
M980	MOUNTING INSTRUCTIONS	1
M1041	LEFT MOUNTING PLATE	1
M1042	RIGHT MOUNTING PLATE	1
M377	8mm x 25mm SS Socket Head Cap Screw	2
M309	8mm x 20mm SS Socket Head Cap Screw	2
R567	7/8" Beveled Socket Washer	4
R501	7/8" Spacer Washer (Upper/thick)	2
R502	7/8" Spacer Washer (Lower/thin)	2
M310	3/16" Short Arm Allen Wrench	1
M311	6mm Short Arm Allen Wrench	1
M313	3/16" Short Arm Allen Wrench Cover	1

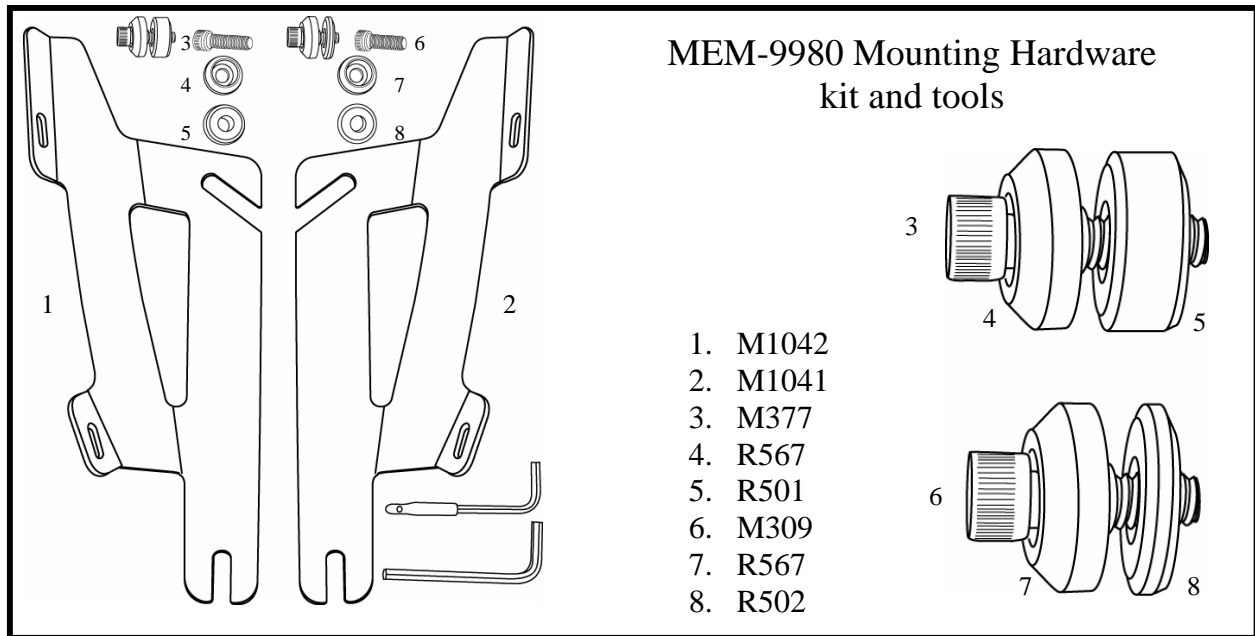

Memphis Shades warrants all product components, metal and plastic, against defects in materials and workmanship for 24 months.

FOR PARTS AND WARRANTY HELP, CONTACT:

MEMPHIS SHADES

P. O. Box 429

Rossville, TN 38066

(901) 853-0293

Visit us on the web at www.memphisshades.com or

you can also reach us at

customerservice@memphisshades.com